

SCALA - LT

PTZ HYBRID / Fiber INTERFACE

PTZ Hybrid or Fiber-Pair Link Single or Dual Channel

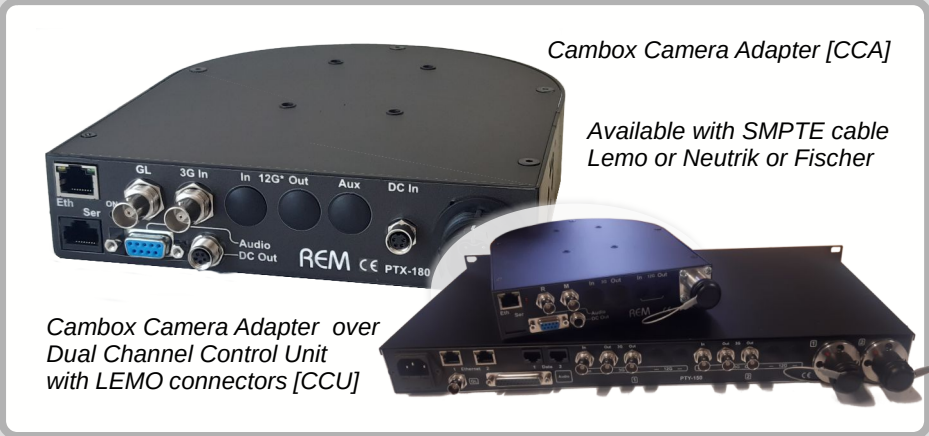

Scala LT Description

Scala LT is the light version of Scala Modular System. It has been developed to use High End PTZ Cameras via hybrid cable (Power+Fiber) handling all necessary signals required in live events. Typical application are Fly-Cases, OB-Vans and Theatres installation. Just Two main option:

- SDI 12G for top quality installations and return 3G SDI
- Two possible Hybrid Connectors: SMPTE 304 (Lemo) or Neutrik DUO

Remote Hybrid Power Unit (ORH or WB) allow very flexible installation. Scala LT may be also ordered with hybrid connectors directly mounted on CCU.

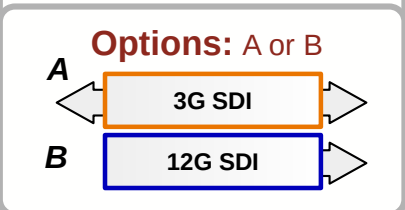
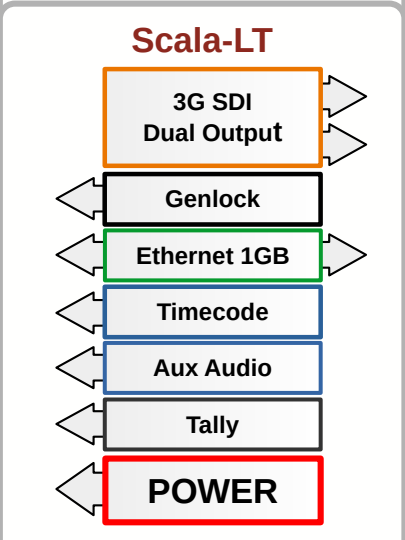
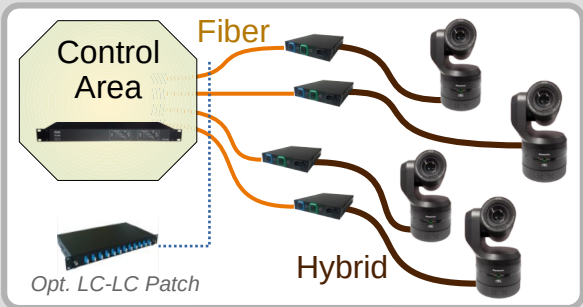
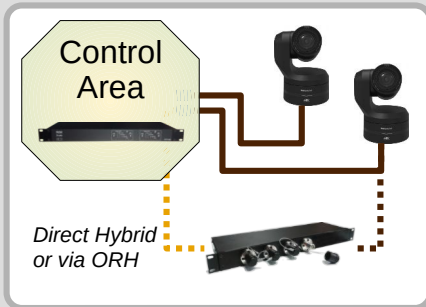

Hybrid Power Units
Manage power to CCA/ PTZ

HPU-WB Wall Box (½RH)
Single/Dual Channel Hybrid Interface

ORH Unit
Host up to 4Ch Hybrid Interface (1RU)

HPU with Neutrik DUO

Wall Box Plus (coming)
Return Video Outputs (BNC) available on HPU-WB
Power On/Off from CCU

ORH with four LEMO

For Full Featured Version see **SCALA** (Modular)

More Videos Audios (Mic) and Data Configurable

Cambox SCALA LT

PTZ HYBRID / Fiber INTERFACE

SCALA LT or ST Case Studies - Applications

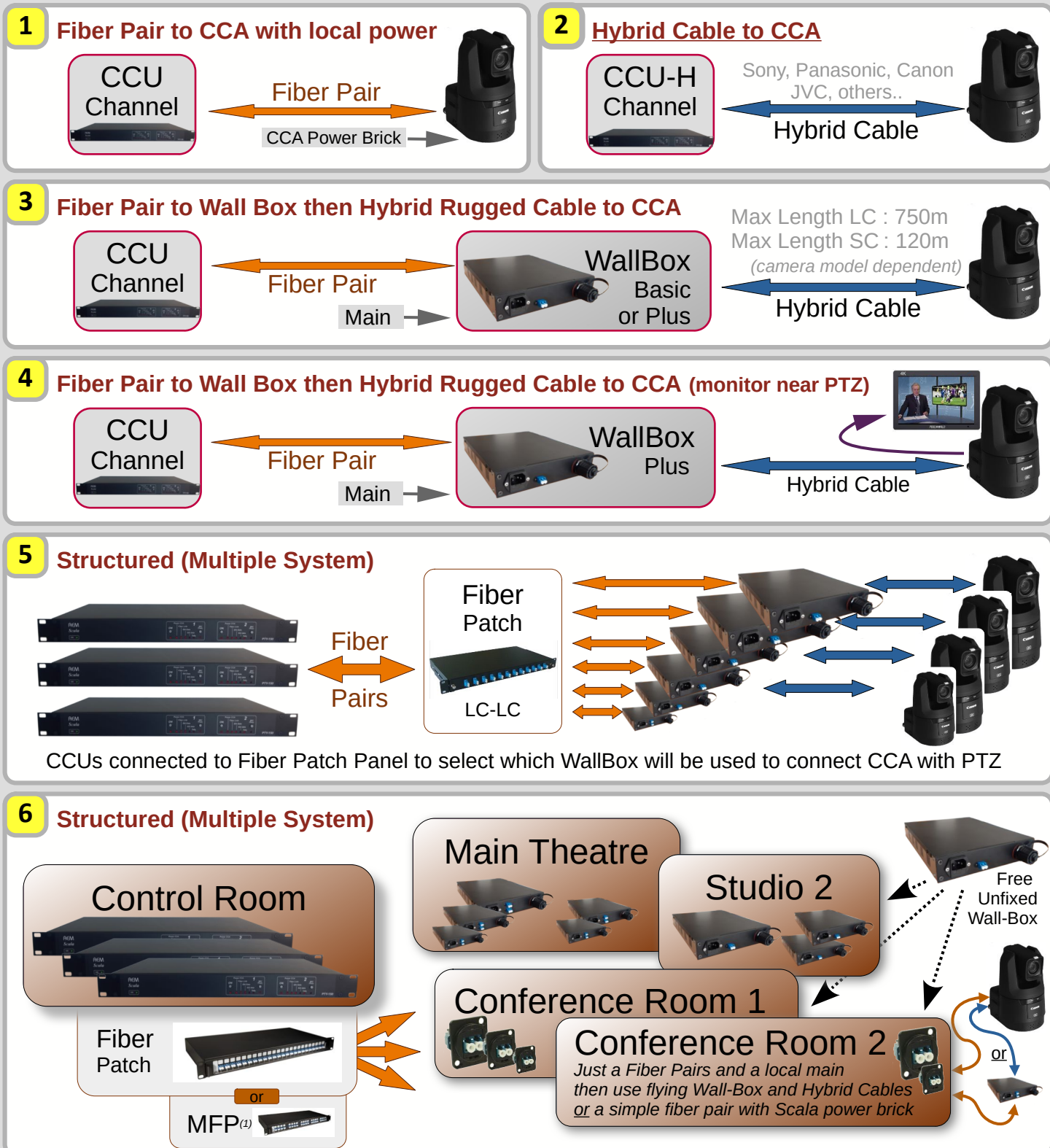

Scala - ST

Scala Studio - Theatre

The **ST version** is similar to LT but it is dedicated to PTZ with less than 30W power consumption and **indoor** short distance application. Using lower cost hybrid connector like Senko or Bulgin allow a sensible cost reduction. All functionalities and options are the same of LT version except the CCU-H (the CCU with Hybrid Connectors)